

PROJECTED CAPACITIVE TOUCH OVERLAY

User manual

Overlay Model number	SONY BRAVIA model compatibility
TO-32BZL-CA10	FW-32BZ30J
TO-43BZL-CA10	FW-43BZ30L
TO-50BZL-CA10	FW-50BZ 30L/35L/40L
TO-55BZL-CA10	FW-55BZ 30L/35L/40L
TO-65BZL-CA10	FW-65BZ 30L/35L/40L
TO-75BZL-CA10	FW-75BZ 30L/35L/40L
TO-85BZL-CA10	FW-85BZ 30L/35L/40L



Table of contents

1.	Important information.....	2
2.	Safety rules.....	3
3.	Box content	4
4.	Nomenclature and functional description	4
5.	Preparing for the installation	5
6.	Installation of the overlay on a screen	6
7.	First start-up and troubleshooting	7
8.	Technical specifications	10
9.	Contact data and manufacturer's information	11

1. Important information

Purpose of the product:

The touch overlay is an electronic device which after the installation on a monitor and connecting it to a computer interacts with it and enables presentation, transmission of information, running of the computer software as well as the educational and entertainment applications dedicated for usage in public utility facilities by means of touch interface. The device supports all touch functionalities of Windows system including browsing the Internet and allows operation of installed applications.

Before using the device please take the time to familiarize yourself with the following information. Please keep this manual for future reference.



THIS SYMBOL ALERTS THE USER THAT THE MANUAL CONTAINS THE IMPORTANT INFORMATION CONCERNING THE HANDLING OF DEVICE PARTS AND CRUCIAL OPERATIONS. THE USER SHOULD BE FAMILIAR WITH THE DOCUMENTATION IN ORDER TO AVOID FURTHER PROBLEMS.



THIS SYMBOL INFORMS THAT THE PRODUCT MUST NOT BE DISPOSED WITH HOUSEHOLD WASTE. DISPOSE WASTE ACCORDING TO NATIONAL REGULATIONS IN ORDER TO AVOID POSSIBLE, NEGATIVE EFFECTS ON ENVIRONMENT AND HUMAN HEALTH. FOR FURTHER INFORMATION CONTACT LOCAL AUTHORITIES, A COMPANY COLLECTING WASTE OR A SUPPLIER.



DIRECTIVE EMC **2004/108/WE** IN THE FIELD OF ELECTROMAGNETIC COMPATIBILITY, DIRECTIVE WEEE **2012/19/UE** ON WASTE ELECTRICAL AND ELECTRONIC EQUIPMENT AND DIRECTIVE ROHS **2011/65/UE** ON THE RESTRICTION OF THE USE OF CERTAIN HAZARDOUS SUBSTANCES IN ELECTRICAL AND ELECTRONIC EQUIPMENT.



DIRECTIVE EMC **2004/108/WE** IN THE FIELD OF ELECTROMAGNETIC COMPATIBILITY, DIRECTIVE WEEE **2012/19/UE** ON WASTE ELECTRICAL AND ELECTRONIC EQUIPMENT AND DIRECTIVE ROHS **2011/65/UE** ON THE RESTRICTION OF THE USE OF CERTAIN HAZARDOUS SUBSTANCES IN ELECTRICAL AND ELECTRONIC EQUIPMENT.

ATTENTION:

IN ORDER TO AVOID THE RISK OF FIRE OR ELECTRIC SHOCK DO NOT PLACE THE DEVICE NEAR HEATERS, AIR-CONDITIONING UNITS, SOURCES OF WATER, CHEMICAL AGENTS, DEVICES WITH MAGNETS OR DEVICES WHICH GENERATE A MAGNETIC FIELD.

ALL REPAIRS MUST BE PERFORMED BY THE QUALIFIED STAFF

The warranty does not cover repair costs in case of:

- a) A removed, modified or illegible Product serial number
- b) Damage or incorrect working resulting from:
 - Accidental damage, misuse, fire, overload of electricity network, other nature forces, unauthorized product modification or failure to comply with the instructions included in this manual.
 - Repairs or repair attempts conducted by unauthorized by manufacturer company person.
 - Damage of the product due to improper transportation.
 - Damage of the product due to relocation or installation.
 - Usage of parts or elements which parameters vary from these recommended by manufacturer.



The manufacturer accepts no responsibility for damage caused by improper use of a device and such damages do not form a valid basis for a claim or warranty repairs.

2. Safety rules

Touch Overlay as any electronic device shall be used for its intended purpose. Carefully read the below security instructions in order to avoid possible injuries and minimize the risk of device damage.

- a) Before using the touch overlay make sure that all protection handles which fix the overlay to a monitor are in a closed position.
- b) If the glass surface of the overlay breaks, handle it with care.
- c) Maintenance and all repairs must be conducted by the qualified technicians of manufacturer.

It is forbidden to:

- a) Make attempts to service a damaged unit yourself.
- b) Pour any liquids to the housing of the device or use the device near liquid. Flood the elements of electronics inside the device housing as this can lead to electric shock, fire or device damage.
- c) Assemble the device alone without any assistance.
- d) Install the device outside a dry, free of dustiness and moisture room.
- e) Use the device outside.
- f) Use the broken device.

The manufacturer accepts no responsibility for software installed by the user as well as the damages made by computer viruses.

3. Box content

Item	Quantity
Touch overlay	1
Top mounting bracket	2-4
Bottom mounting bracket	2-4
IR remote repeater	1
Manual	1
Philips screws (including spares)	30
Philips screwdriver	1

4. Nomenclature and functional description

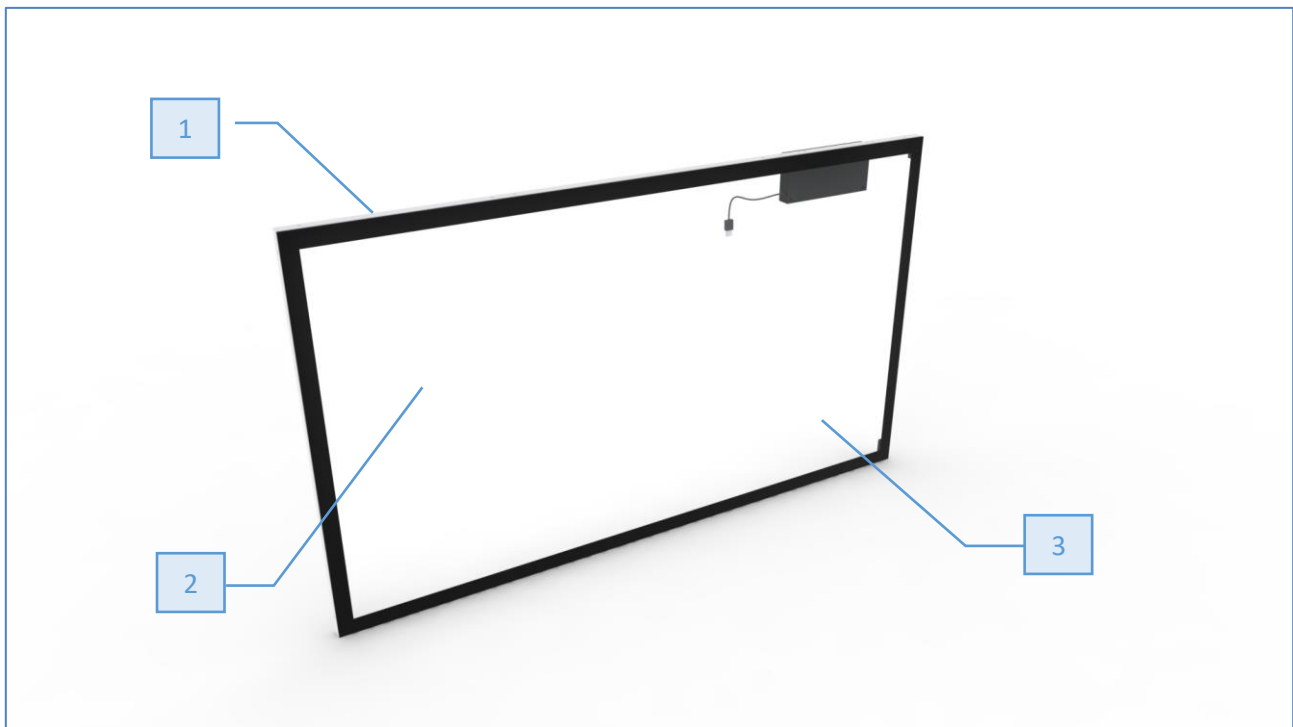

	Item description
1	Frame – the main constructional element of the overlay
2	Working surface – made out of tempered glass, here the touch operations take place
3	Touch foil – laminated to the rear surface of glass allow detection of the touch point through the glass itself

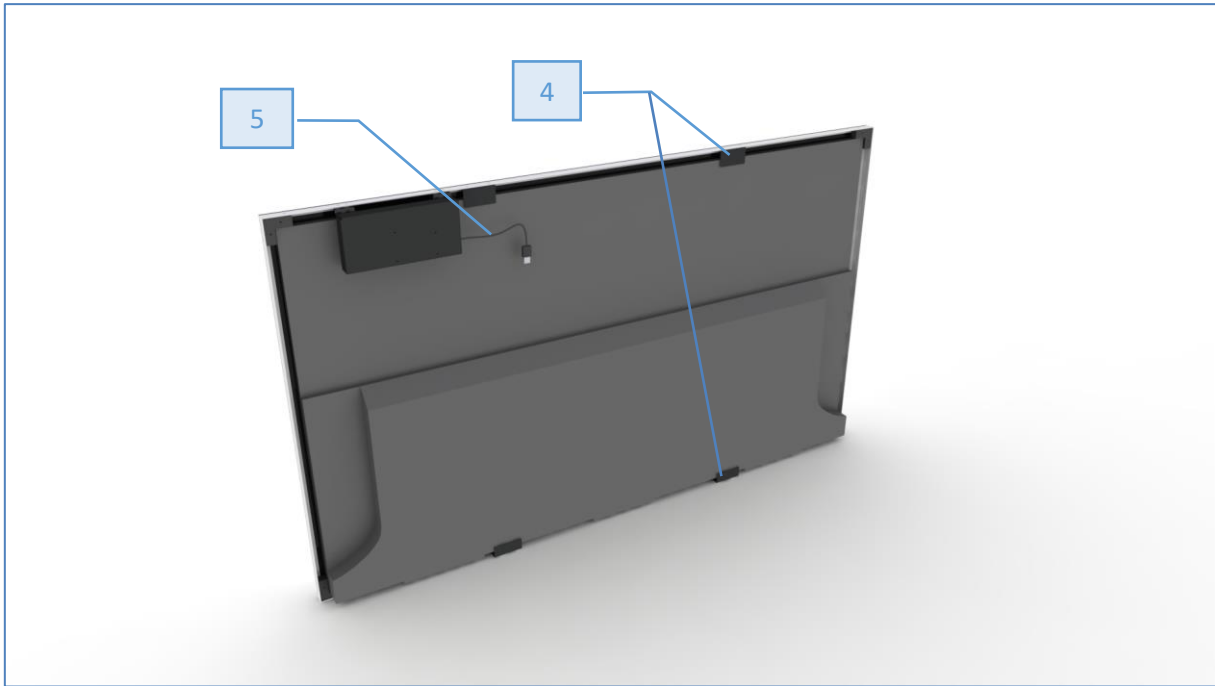

Item description	
4	Mounting bracket – element which allows easy installation of the overlay on a monitor and safe use
5	USB plug – connected to a computer, allows the communication between the overlay and a computer operating system

5. Preparing for the installation

Before installation, make sure that the following conditions are met:

- a) There is enough space to maintain safe installation.
- b) Free access to a monitor on which the overlay will be installed is provided.
- c) Users familiarized themselves with the installation instructions which are part of this manual.

General advice:

- a) Tapes around the box must be cut carefully in order to avoid damage of the packaging and its content.
- b) After opening the box, make sure that the overlay is free from damage.

6. Installation of the overlay on a screen

ATTENTION: In order to avoid damage to the product, the installation should be done by at least two persons.



- a) Check the general condition of the overlay after unpacking it then take out the mounting brackets and M3 screws.



- b) Peel of protection film from the inner side of the glass starting from the marked corners.
c) Install the overlay on a screen. Be careful to avoid damage of a fragile matrix.

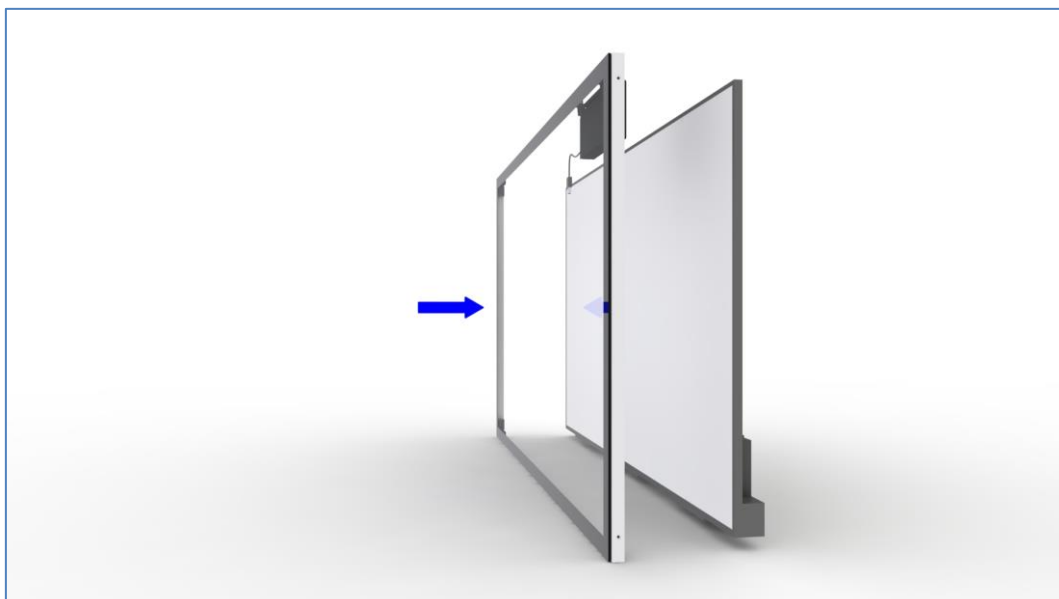

- d) After installing the overlay on a monitor, fix top and bottom brackets.

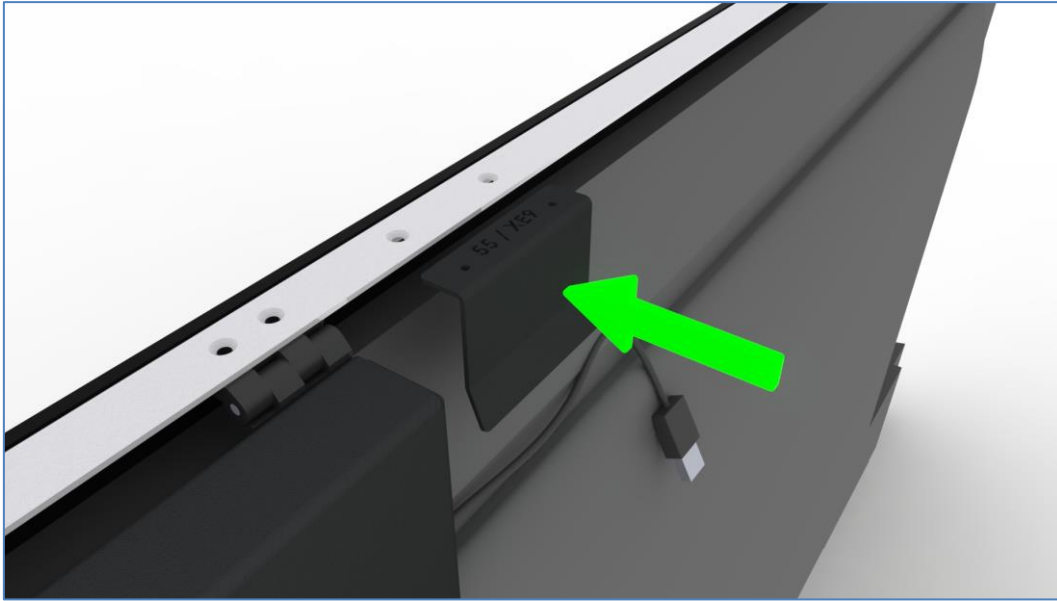

e) Connect the USB cable to a computer*



* For 75 and 85 inch overlay there are 2 (two) USB cables that need to be connected. One for communication and second for power supply.

7. First start-up and troubleshooting

The device does not require any additional driver. It is ready for operation straight after connecting it to a computer with supported OS.

	Multi-touch capabilities
Windows XP, 2000, VISTA *	○
Windows 7 Starter, Home Basic *	○
Windows 7 Home Premium, Professional, Enterprise, Ultimate *	●
Windows 8, 10 *	●
MAC OS 10.9 **	● (supports full Multi-touch gestures)
MAC OS 10.10 **	● (supports basic Multi-touch gestures)
Android 4.0 or later ***	●
Linux 3.0 or later ****	●

* Windows version must not be OEM version

** Dedicated driver is required to make Multi-touch available on Mac OS

*** If Linux kernel is configured not to load HID MULTITOUCH driver, Multi-touch is not available. Please change kernel configuration to load HID MULTITOUCH driver

**** Depending on version kernel configuration may need to be changed to load HID MULTITOUCH driver.

If your device does not work properly, please check bellow section for possible solutions. If problem persists please contact SONY PRIME SUPPORT.

- **The touch screen does not detect touch**
 - Disconnect the overlay and connect it again to the computer
 - Connect the overlay to another USB port of the computer
 - Restart the computer
- **Windows (version 7, 8, 10) system does not start properly**
 - Disconnect the overlay before powering the computer up
- **Cursor does not accurately follow your finger**

Please follow these steps to re-calibrate the device:

1. Open **Control Panel**.
2. Click on **Hardware and Sound**.
3. Under "Tablet PC Settings," click the **Calibrate the screen for pen or touch input** link.

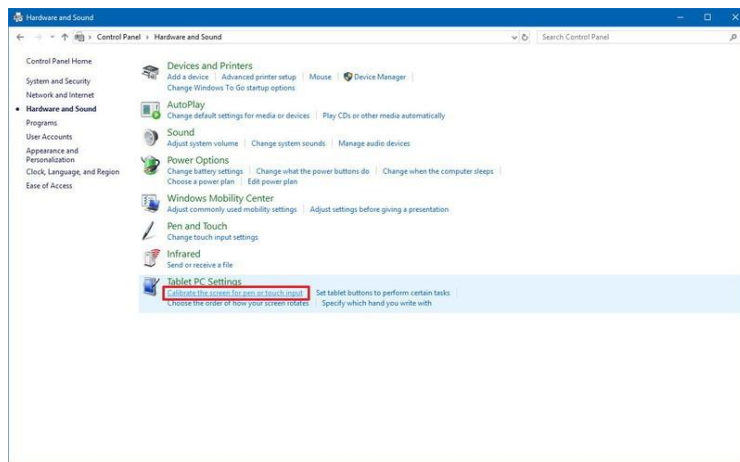

4. Under "Display options," select the display (if applicable).

Quick Tip: Under "Details," you can tell whether your screen has full support for pen and touch with Windows 10.

5. Click the **Calibrate** button.

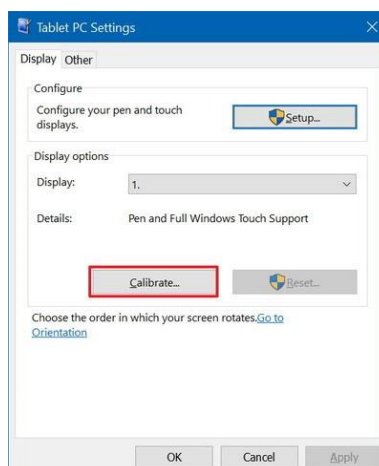

6. Select the **Touch input** option.

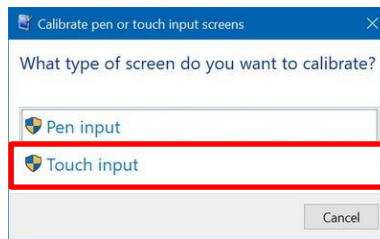

7. In the white screen, tap the **crosshair** each time that it appears on the screen, and do not change the resolution during this process.



8. After the calibration process concludes, you'll be given the choice to **save the calibration data**.

Once you've completed the steps, your touch overlay should accurately register touch inputs.

- **SONY BRAVIA Remote does not work properly.**
 - Remove **IR remote repeater** being part of the set from the accessories box



- Attach **Receiver (1)** to the external side of Touch frame using double sided tape

Quick Tip: Check if remote controller works properly with the Receiver placed in desired position prior to attaching it with double sided tape.

- Attach **Emitter (2)** to the internal side of Touch frame near SONY BRAVIA IR sensor using double sided tape
- Connect device to available SONY BRAVIA USB port using **USB cable (3)**

8. Technical specifications

Touch specifications:

Technology				Power		Environment				
Touch technology	Number of touch points	Response time	Max touch point accuracy	Touch durability	Power input	Power	Operating temperature	Storage temperature	Operating humidity	Storage humidity
Projected Capacitive	10	5 - 16 ms	3 mm	Unlimited	USB HID. No driver required	<2 W	-20°C – 60°C	-20°C – 60°C	10% – 90% RH	10% – 90% RH

Mechanical specifications:

Product name	Overlay specifications				Dimensions		Weight (Approximate)	
	Diagonal	Compatibility	Bezel size	Glass Thickness	Overlay (W x H x D)	Package (W x H x D)	Overlay	Package
TO-32BZL-CA10	32"	FW-32BZ30J	30 mm	4 mm	756 x 456 x 76 mm	900 x 600 x 150 mm	5 kg	7 kg
TO-43BZL-CA10	43"	FW-43BZ30L	30 mm	4 mm	1010 x 598 x 60 mm	1100 x 720 x 150 mm	8 kg	11 kg
TO-50BZL-CA10	50"	FW-50BZ 30L/35L/40L	30 mm	4 mm	1171 x 691 x 60 mm	1250 x 790 x 150 mm	9,5 kg	12 kg
TO-55BZL-CA10	55"	FW-55BZ 30L/35L/40L	30 mm	4 mm	1272 x 747 x 60 mm	1370 x 880 x 150 mm	11,5kg	15 kg
TO-65BZL-CA10	65"	FW-65BZ 30L/35L/40L	36 mm	4 mm	1502 x 877 x 60 mm	1610 x 1010 x 150 mm	16 kg	20 kg
TO-75BZL-CA10	75"	FW-75BZ 30L/35L/40L	51 mm	4 mm	1757 x 1035 x 65 mm	1820 x 1130 x 150 mm	24 kg	29 kg
TO-85BZL-CA10	85"	FW-85BZ 30L/35L/40L	68 mm	4 mm	2012 x 1182 x 65 mm	2030 x 1250 x 150 mm	35 kg	45 kg

9. Contact data and manufacturer's information

- **Maintenance**

The device does not require user maintenance. Pay attention to cleanliness of a housing, in particular, the cleanliness of touch components which are placed around the working surface. Do not clean the device using tap water, aggressive cleaning agents or products with abrasive properties as they can easily damage the device surface.

- **PrimeSupport contact details**

All Touch overlays sold into the EU, Norway and Switzerland come supplied with a 3 Year PrimeSupport pack, offering unique services and benefits, including:

- Freephone telephone helpdesk support in 5 languages.
- Receive a completely new replacement model rather than repair as standard.

Contact details:

Language	Location	Telephone number	Email
German	Germany	+49 (0)69 945 18 93 47	elitesupport.de@sony.com
French	France	+33 (0)1 86 99 55 96	elitesupport.fr@sony.com
Italian	Italy	+39 06 893 863 47	elitesupport.it@sony.com
English	Great Britain	+44 (0)20 3901 5561	elitesupport.en@sony.com
Spanish	Spain	+34 (0)91 836 29 66	elitesupport.es@sony.com

**Opening hours: Monday- Friday 9:00 – 18:00 CET (Central European Time), excluding Local National Holidays. You will need to provide the following information:*

1. *The name/model number of the product(s)*
2. *The serial number(s)*
3. *A copy of the invoice from the supplier you purchased your product(s) from*
4. *Your contact details*

- **Manufacturer information:**

Videofonika Sp. z o.o. sp.k

ul. Przemysłowa 8
32-540 Trzebinia
woj. Małopolskie
POLAND

www.videofonika.pl

